

→ CARTON EDGE SEALER

CHS-6702

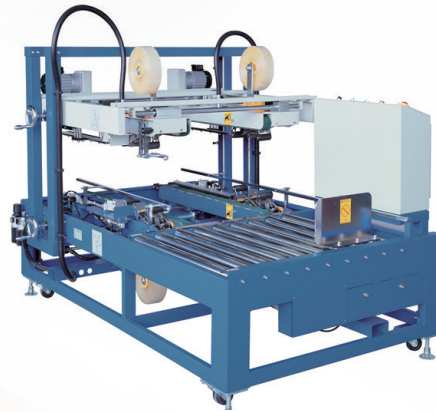

CHS-6702A

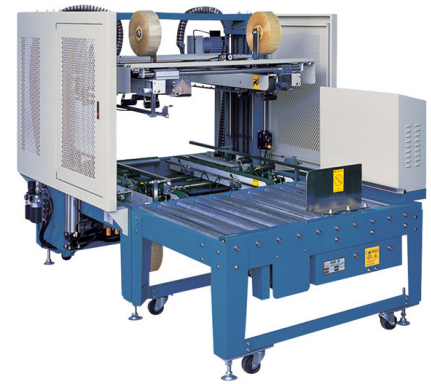

CHS-6702

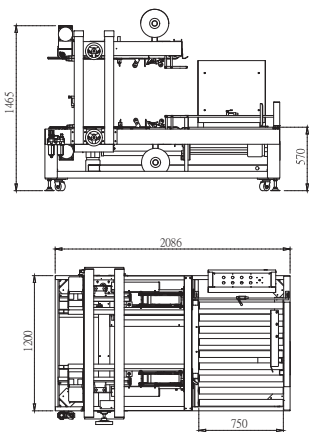

CHS-6702A

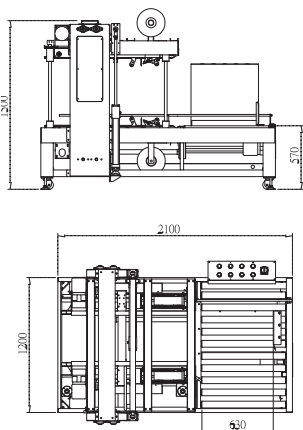

CHS-6702 UNIFORM CARTON EDGE SEALER

CHS-6702 FEATURES

Fast and easy box width changes
Box height adjustment by motor-driven(move up/down)
Industrial strength top and bottom belts
To seal the box's four edge continuously
Adjustable leg extensions
Reset button
Emergency stop button
Includes a front side entry for a 90 degree directional carton turn before entering into the four edge sealing station"

CHS-6702 EDGE TAPING SPECIFICATION

Sealer Type	Top and bottom belt carton sealer
Power Supply	3 phase,220V/380V, 50/60HZ
3" Tape Sealing Size	L280mm - 700mm, W250 - 600mm,H200 - 600mm
Tape Overlap	L60±5 (mm) standard
Working Table Height	570-770mm
Belt Speed	20M/min.
Air Compressor	6kg/cm2
Capacity	18 cases/per min. depending on box size and operator efficiency.

CHS-6702A RANDOM CARTON EDGE SEALER

CHS-6702A RANDOM FEATURES

Accommodates variety of box sizes
Adjustable operator-free
SMC brake cylinder
Random / Uniform mode selection
Industrial strength top and bottom belts
To seal the box's four edge continuously
Adjustable leg extensions
Includes a front side entry for a 90 degree directional carton turn before entering into the four edge sealing station

CHS-6702A RANDOM TAPING SPECIFICATION

Sealer Type	Top and bottom belt carton sealer
Power Supply	3 phase,220V/380V, 50/60HZ
3" Tape Sealing Size	L280mm - 630mm, W250 - 600mm,H225 - 600mm
Tape Overlap	L60±5 (mm) standard
Working Table Height	570-770mm
Belt Speed	20M/min.
Air Compressor	6kg/cm2
Capacity	6 cases/per min. depending on box size

