

CHS-6801

AUTOMATIC CARTON ERECTOR

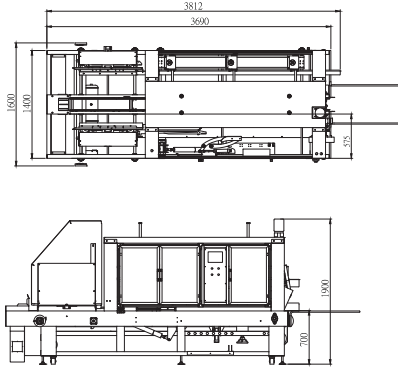

CHS-6801

AUTOMATIC CARTON ERECTOR (HORIZONTAL TYPE)



CHS-6801L

CHS-6801L

AUTOMATIC CARTON ERECTOR (HORIZONTAL TYPE)

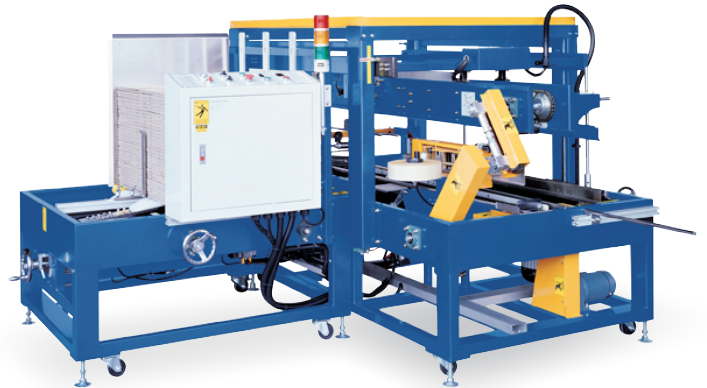
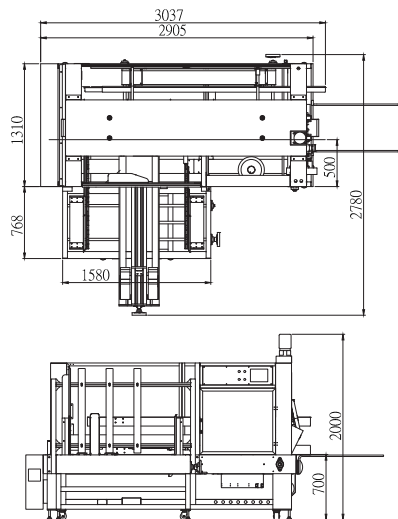

Feature

- Suitable for handling by side loading.
- For general type of corrugated boxes.
- To open and form the box then seal the bottom flaps.
- Positive box opening with opposing vacuum system.
- Capable of folding and sealing boxes with adhesive tape or hot melt glue.
- PLC controlled to alter the program easily.
- HMI control panel.
- Malfunction alarm with Tri-color warning light.
- Detection for low-quantity boxes.
- Reverse feeding direction is available by request.
- Safety interlocked guarding.

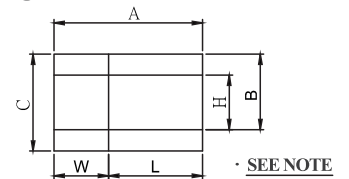

Specification

Model	CHS-6801	CHS-6801L
Type	Horizontal	Horizontal
Power Supply	220V/380V/415V, 3 phase, 50 /60 Hz	220V/380V/415V, 3 phase, 50 /60 Hz
Tape Width	2" or 3"	2" or 3"
Feeding Direction	Straight type	L type
Tape Sealing Size	L260-500mm, W220-400mm, H200-500mm	L300-600mm, W220-500mm, H250-500mm
Working Table Height	700mm	700 mm
Capacity	5-8 boxes/min.	5-8 boxes/min.
Cardboard Storage	50-70 pcs (depends on boxes thickness)	50-70 pcs (depends on boxes thickness)
Machine Dimension	L3812 x W1600 x H1900 mm	L3037 x W2780 x H2000mm
Air Compressor	6kg/cm ²	6kg/cm ²
NOTE	Box dimension must match below format: A=L+W : B=H+W/2 : C=H+W 480mm<A<900mm; 300mm<B<560mm; 400mm<C<750mm.	Box dimension must match below format: A=L+W : B=H+W/2 : C=H+W 520mm<A<1100mm; 300mm<B<560mm; 500mm<C<850mm.

※ CHA Pack reserves the right to modify specification for quality development.

CHS-6701

AUTOMATIC CARTON ERECTOR

CHS-6701

AUTOMATIC CARTON ERECTOR
(VERTICAL TYPE)

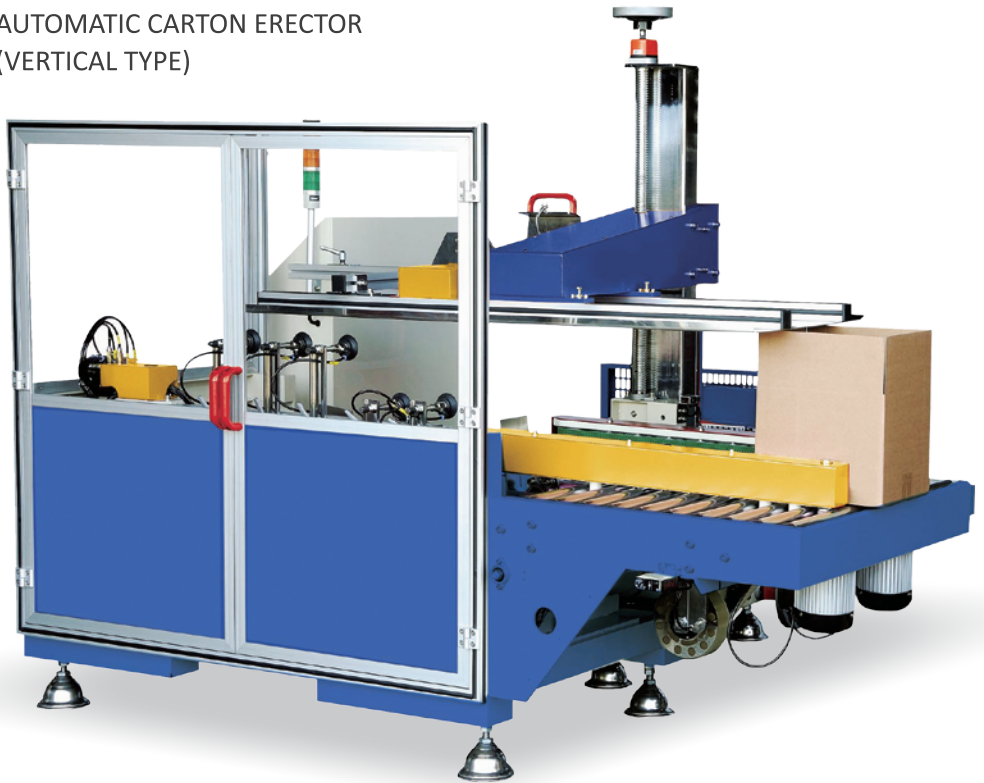
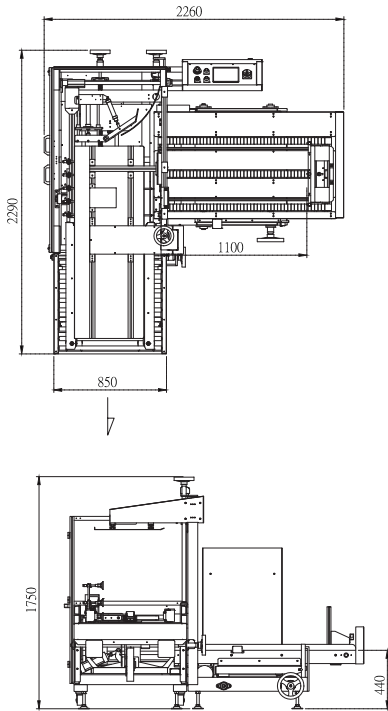

Feature

- For all general type of corrugated boxes.
- To open and form the box then seal the bottom flaps.
- PLC controlled to alter the program easily.
- HMI control panel.
- Easy adjustment for fixed format boxes by handwheels.
- Aluminum frame and acrylic safety fence with shut-off device.
- High speed & durable tape head.
- Suction cup system.
- Malfunction alarm with Tri-color warning light.
- Detection for low-quantity boxes.
- Reverse feeding direction is available by request.

Specification

Model	CHS-6701
Function	Side belt driven
Power Supply	3 phase , 220V /380V /415V , 50 /60 Hz
Tape Width	2" or 3"
Feeding Direction	L type (Left side/ Right side)
Tape Sealing Size	L250-500mm , W170-390mm , H90-500mm
Working Table Height	650mm
Capacity	8-10 boxes/min.
Cardboard Storage	90-100 pcs (depends on boxes thickness)
Machine Dimension	L2290 x W2260 x H1750mm
Air Compressor	6kg/cm ²

※ CHA Pack reserves the right to modify specification for quality development.



www.chuen-an.com

CHUEN AN MACHINERY INDUSTRIAL CO., LTD.
 Address: No.8 Wugong 7th Road, Wufeng Dist., Taichung City, Taiwan 41353.
 Tel: +886-4-2331-8689 | Fax: +886-4-2331-9689 |
 Website: www.chuen-an.com | E-mail : chuenan.intsales@gmail.com
The End-of-Line PACKAGING MACHINE Manufacturer